

# High dynamic range SQUID readout for frequency-domain multiplexers\*

M. Kiviranta

VTT, Tietotie 3, 02150 Espoo, Finland

*A 16-SQUID array has been designed and fabricated, which shows  $0.12 \mu\Phi_0 \text{ Hz}^{-1/2}$  flux noise at 4.2K. The readout amplifier based on a cryogenic silicon-germanium bipolar transistor employs short-delay negative flux feedback and reaches 7 MHz bandwidth for a  $1 \Phi_{0 \text{ p-p}}$  signal. The  $-1 \text{ dB}$  compression is reached approximately at  $4.2 \Phi_{0 \text{ p-p}}$  amplitude when the signal frequency is 1 MHz. In the feedback mode the flux noise is anomalously increased to  $0.35 \mu\Phi_0 \text{ Hz}^{-1/2}$ . PACS numbers: 85.25.Dq, 85.25.Oj.*

## 1. INTRODUCTION

The major bottleneck in implementing Frequency Domain Multiplexers<sup>1</sup> (FDM) for Transition Edge Sensors<sup>2</sup> (TES), such as the European-Japanese Calorimeter Array EURECA<sup>3</sup>, is construction of an amplifier at the signal summing point, which has sufficiently good characteristics. The amplifier must have simultaneously (i) large dynamic range and (ii) bandwidth, as well as (iii) sufficiently low noise temperature to the source impedance presented by the TESes and (iv) low input impedance. SQUIDs are a good choice for requirements (ii - iv) but additional circuitry is needed to meet the point (i). As the traditional flux-locked loop is hardly capable to meet all the requirements, the EURECA consortium has considered three novel approaches: (a) the baseband feedback<sup>1,4</sup>, (b) fine-coarse feedforward<sup>5</sup> and (c) short-delay negative feedback using a cryogenic amplifier, which is evaluated in this work. Short feedback *without* a cryogenic amplifier may be feasible in the current-sampling configuration<sup>4</sup>, in which the SQUID voltage gain  $\partial V / \partial \Phi$  would not reduce. The trade-off between the alternatives is a complicated one, involving e.g. the division of power dissipation into various temperature stages available in the refrigerator, the tolerable nonlinearity level in the FDM system, and parasitics in the implementable interstage wiring.

## 2. SQUID DESIGN AND FABRICATION

---

\* Presented in the 12<sup>th</sup> International Workshop on Low Temperature Detectors (LTD-12), July 22-27 2007, Paris, France.

## M. Kiviranta

The readout circuit utilizes a 16-SQUID serial array, fabricated on a special high-current version of our RSFQubit process<sup>6</sup>. This process has four superconductive Nb wiring layers, Nb-Al/AlOx-Nb trilayer Josephson junctions with  $J_C = 600 \text{ A/cm}^2$  critical current density, and Pd resistors with cooling fins made of  $0.8 \text{ }\mu\text{m}$  thick Cu.

The SQUID washers have a design loop inductance of  $L_{SQ} = 8 \text{ pH}$  from an elongated hole of  $2.4 \times 5 \text{ }\mu\text{m}$  size. The input coil consists of 3 turns, and the coil wire circulates all the washer holes for one turn before progressing to the next turn (fig. 1). This is unlike the standard arrangement where all the turns are completed around one washer before progressing to the next washer. Because the large output voltage across the series-coupled washer chain tends to couple capacitively into the input coil, causing the well known parasitic feedback<sup>7</sup>, this design attempts to prevent excitation of flux-mode currents in the input coil even when the capacitive coupling is present. Our numerical simulations based on a lumped-element feedback model suggest that the noise level does *not* increase in the ‘clean’ negatively fed-back slope of the  $V-\Phi$  characteristics even though an instable region and a plateau is created in the positively fed-back slope. Still, it is conceivable that transmission line modes at higher frequencies than the lumped-approximation LC resonance cause sufficient phase shift for the positive feedback condition at some frequency on both slopes, so that it appears wise to try to avoid such feedback altogether.

Noticing that the strength of the parasitic feedback is proportional to the product of  $dV/d\Phi$  (whose large value is one motivation to build SQUID arrays in the first place) and mutual inductance  $M_C$  between the input coil and the SQUID array,  $M_C$  is kept low by using a 3-turn coil only. The designed mutual inductances  $M_I$  from the inputs to the SQUID array are then reached by use of an intermediate transformer. Our device, designed with the fine-coarse feedforward in mind, has two tight-coupled inputs with  $M_{I,1}^{-1} = 9 \text{ }\mu\text{A}/\Phi_0$  and  $M_{I,2}^{-1} = 36 \text{ }\mu\text{A}/\Phi_0$  for signals, and a loose-coupled  $M_{I,3}^{-1} = 38 \text{ }\mu\text{A}/\Phi_0$  input for flux feedback.

The unanticipated outcome of the non-standard input coil geometry was introduction of a parasitic output-to-voltage feedback mode. The new mode effectively adds the wire-to-washer capacitance in parallel to the junction capacitance, an effect which gets multiplied by a factor proportional to  $N$  in an  $N$ -SQUID array. As a result, the  $V-I$  characteristics were strongly hysteretic at the design value of the junction critical current  $I_C = 52 \text{ }\mu\text{A}$ . The remedy was annealing the chips in nitrogen atmosphere at  $210 \text{ C}$  for 90 minutes, which reduced the critical current into  $I_C = 36 \text{ }\mu\text{A}$ . The characteristics of the annealed device are shown in figures 1 and 2.

## High dynamic range SQUID readout for frequency domain multiplexers

Regularity of the wide-range flux-to-voltage characteristics indicates closely matched washer inductances.

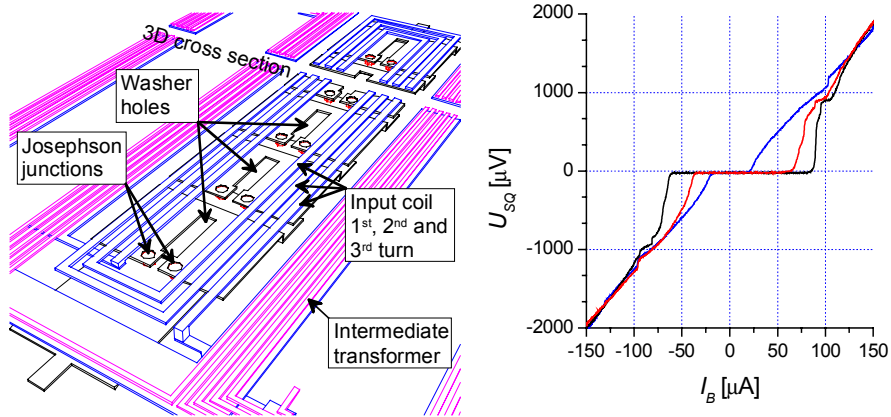

Fig. 1. Left: Simplified view of the SQUID array construction. Right: SQUID array voltage as a function of bias current  $I_B$ , when the applied flux is integer, half-integer and quarter-integer flux quantum.

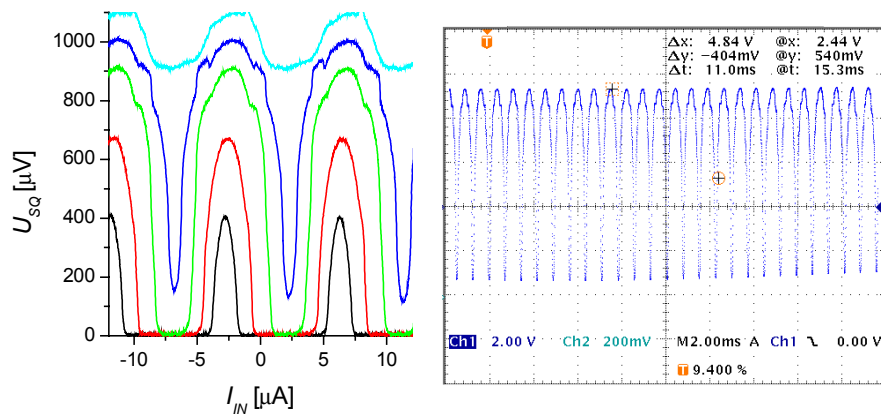

Fig 2. Left: SQUID array voltage as a function of input current  $I_{IN}$  when bias current is  $I_B = 40, 60, 70, 80$  and  $100 \mu\text{A}$ . Right: flux-to-voltage characteristics over  $26 \Phi_0$  range.

### 3. CRYOGENIC POST-SQUID AMPLIFIER

We have been developing a low-dissipation dc-coupled cryogenic amplifier based on a long-tailed pair of discrete silicon-germanium (SiGe)

## M. Kiviranta

heterojunction bipolar transistors. At the time of this writing its stability at 4.2K still needs improvement. Thus, for the measurements at hand we have used our old electronics<sup>8,9</sup>, consisting of a single ac-coupled SiGe transistor at 4.2 K and a separate dc-coupled INA103 amplifier at 300 K for the SQUID setpoint control (fig. 3). Useful SiGe transistors for low-noise operation at 4.2 K include BFP650 and NESG3031, while some other types have a larger noise, and still others (such as BFR705 and BFR750) freeze out at 4.2 K. The transistor output is coupled to a short-delay flux feedback path which can be activated via a CMOS switch at 4.2 K.

The amplifier is installed in a dipstick wired by 1 m long twisted pairs. Because the dominant pole of the flux feedback path is formed by the cable capacitance leading to the collector bias resistor at 300 K<sup>8</sup>, pole location (and loop stability) can be affected during an experiment by adding varying capacitance at the 300K end of the cable.

## 4. EXPERIMENTS

Measurements were performed with transistor collector current  $I_T = 3.2$  mA and at a low SQUID bias current  $I_B = 65$   $\mu$ A to avoid the formation of a kink to the  $\Phi$ -V slope. The open-loop noise measurements (fig. 3) were performed on a low-voltage setpoint for the applied flux  $\Phi_A$  which yielded a large gain  $dV/d\Phi = 9.9$  mV/ $\Phi_0$ . At this gain the 1 nV/Hz<sup>1/2</sup> voltage noise due to the INA103 should not contribute much to the total noise. No systematic search was performed to find the lowest-noise  $\Phi_A$ - $I_B$  combination.

For the closed-loop experiment the  $\Phi_A$  was adjusted to the center of the  $\Phi$ -V slope in order to maximize the dynamic range. It is not known at the moment whether the increase in the flux noise (fig. 4) is due to the different setpoint or whether it is related to the dynamics of the feedback operation.

Frequency response of the SQUID-amplifier combination (fig. 4) was measured with HP89410 vector signal analyzer, using a frequency chirp with 1  $\Phi_0$  peak-to-peak amplitude as the excitation. To assess the combined non-linearity of the SQUID and the SiGe transistor, a sinusoidal 1 MHz excitation was arranged and its peak-to-peak amplitude varied from 1 to 4.5  $\Phi_0$  while the spectrum of the output signal was recorded. The observed levels of the fundamental, the 2<sup>nd</sup> harmonic and the 3<sup>rd</sup> harmonic are depicted in figure 5. -1 dB compression point can be interpolated to 4.2  $\Phi_0$  p-p amplitude. The response to a 500 kHz square wave with 1  $\Phi_0$  p-p amplitude as the excitation gives an indicates 20  $\Phi_0/\mu$ s slew rate (fig. 5).

## 5. DISCUSSION

## High dynamic range SQUID readout for frequency domain multiplexers

These first results from the array SQUID are encouraging even though the slew rate is worse than one obtained in refs. 9 and 10. The main reason was introduction of an instability when a larger loop gain was attempted by reducing the flux feedback resistor value. The huge combined gain of the SQUID array and the transistor probably gives rise to parasitic feedback mechanisms. A more careful circuit layout may make larger loop gains feasible.

The parasitic feedback mechanisms may also play a role in the increase of the flux noise level when the loop is closed. Further work is needed to reveal the mechanism. Even in its current shape the circuit delivers significantly higher bandwidth / dynamic range combination than fastest systems based on room-temperature feedback<sup>11</sup>.

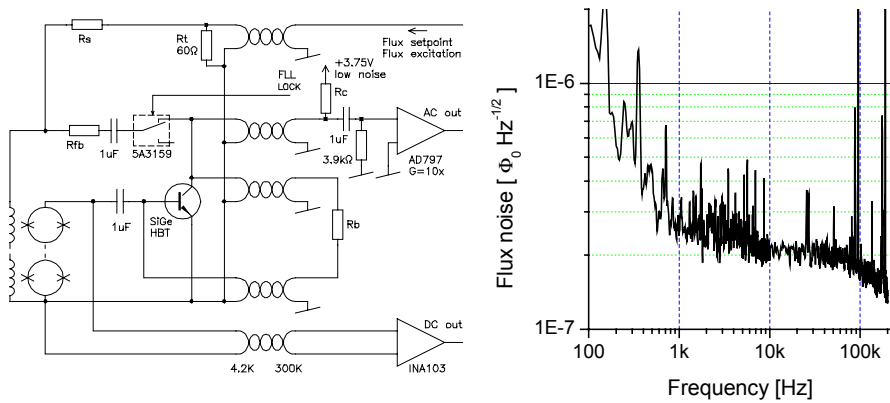
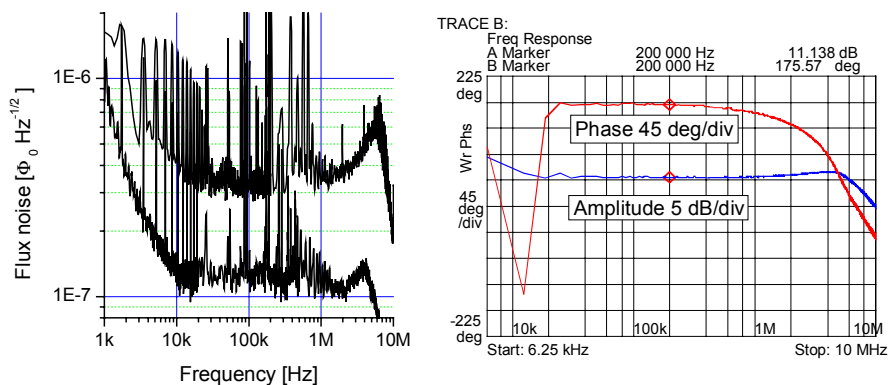

Fig. 3. Left: simplified schematic of the experimental setup. Right: flux noise of the array SQUID when operated without feedback, as measured through the INA103 instrumentation amplifier.



## M. Kiviranta

Fig. 4: Left: noise spectrum of the SQUID read through the SiGe transistor when the feedback is switched on (upper trace) and off (lower trace). Right: frequency response excited by a chirp with  $1 \Phi_{0 \text{ p-p}}$  amplitude.

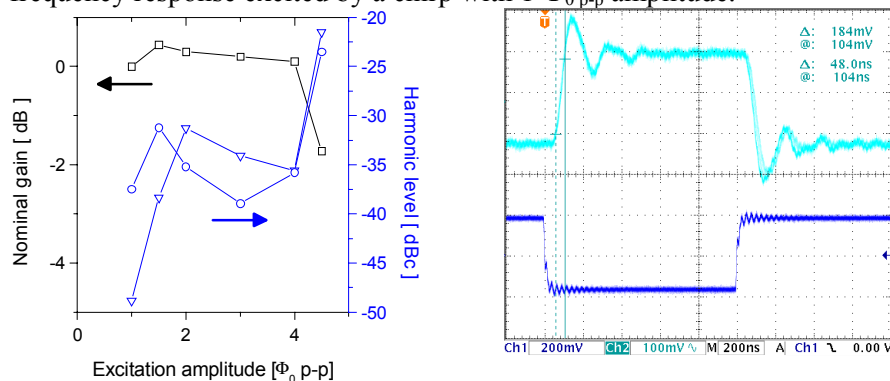

Fig. 5: Left: linear gain ( ) and generated 2<sup>nd</sup> (°) and 3<sup>rd</sup> (∇) harmonics as a function of the peak-to-peak amplitude of a 1 MHz sinusoidal excitation. Right: time-domain response to a  $1 \Phi_{0 \text{ p-p}}$  square wave at 500 kHz.

## ACKNOWLEDGEMENTS

The author thanks P. Immonen for annealing the samples and J. Hassel for the general help in experiments. This work was supported by the Centre of Excellence for Low Temperature Quantum Phenomena.

## REFERENCES

1. M. Kiviranta, H. Seppä, J. van der Kuur and P. de Korte, *AIP Conference Proceedings* **605**, 295 (2002). See also the LTD-9 viewgraphs, downloadable at [www.iki.fi/msk/xeus](http://www.iki.fi/msk/xeus).
2. K. Irwin and G. Hilton, *Topics in Applied Physics* **99**, 63 (2005).
3. P. de Korte et. al., *Proc. SPIE* **6266**, 62661Z (2006).
4. J. van der Kuur, M. Kiviranta and P. de Korte, report *SRON-CIS-Rep-WP-511* (2002), unpublished.
5. Jan van der Kuur, private communication (2005).
6. L. Grönberg, J. Hassel, P. Helistö and M. Ylilammi, *Applied Superconductivity Conference ASC'2006*, accepted to *IEEE Tran. Appl. Supercond.* (2007).
7. T. Minotani, K. Enpuku and Y. Kuroki, *J. Appl. Phys.* **82**, 457 (1997).
8. M. Kiviranta, *Proc. 4<sup>th</sup> Int. Workshop Low Temp. Electronics (WOLTE-7)*, 21-23 June 2006.
9. M. Kiviranta, *Supercond. Sci. Tech.* **19**, 1297 (2006).

**High dynamic range SQUID readout for frequency domain multiplexers**

10. D. Drung et. al., *Applied Superconductivity Conference ASC'2006*, accepted to *IEEE Tran. Appl. Supercond.* (2007).
11. T. M. Lanting et. al. *Appl. Phys. Lett.* **86**, 112511 (2005).